

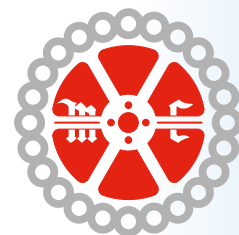

WOVEN APPAREL

Raising
Shearing
Brush Sueding
Diamond Emery



MARIO CROSTA
SINCE 1925

RAISING

Single drum raising machine MC 10/28 - MC 10/36



These single drum machines are suitable for processing all types of woven fabrics made from natural or synthetic fibre.

They are available with 28 or 36 raising rollers, with a ranging from 1800 to 3600 mm to better adapt to fabrics of any width.

Equipped with an automatic zero point setting device.

As optional, thanks to the special **Seam Jumper®** (Crosta's patent) device for the automatic jumping of seams, production rejections around seams are eliminated and seams do not need to be repeated.

All raising parameters can be set both during machine standstill and while working.

PLUS

- » **Automatic control device** for cleaning brushes.
- » **Semi-automatic drawing-in** device.
- » **Pneumatic tension control** of raising cylinders driving belts.
- » Impulse running of each device **with independent driving system**.
- » **Working hours counter** for preventive maintenance control.
- » **Touch-screen display** to guide and assist the operator during each operation phase.
- » Programmer able to **record up to 400 work programs**.
- » **Driving system** with inverter-controlled three-phase motors and DC bus system.
- » An **air conditioner** installed on the upper section of the electric control box **keep the temperature constant** and **avoid the formation of condensate**, thus ensuring a long duration of all electric and electronic components.

Technical data

Installed power	45 kW
Effective energy consumption	20 kW
Compressed air min. pressure	5 bar
Adjustable production speed	10-40 m/min
Drum speed	70-120 rpm
Machine width	1800-3600 mm

Impact on the environment Compliant with all safety, EMC and noise European standards.

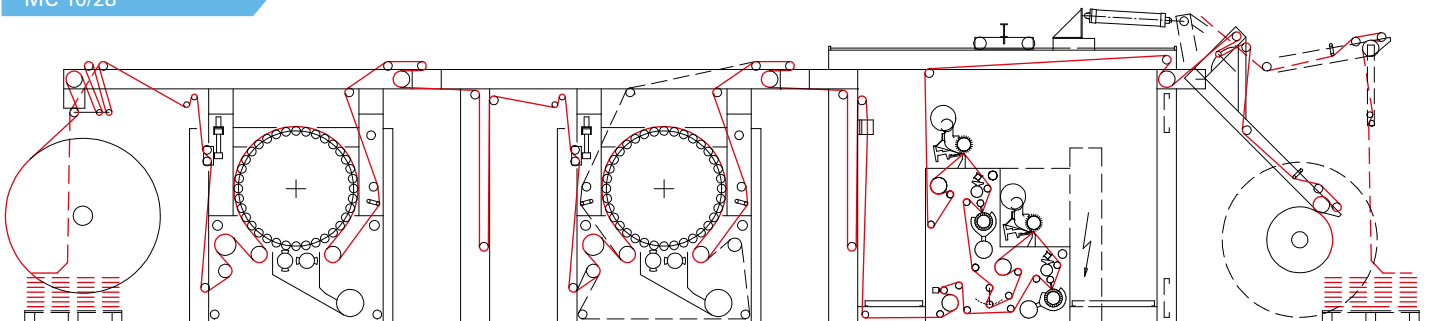
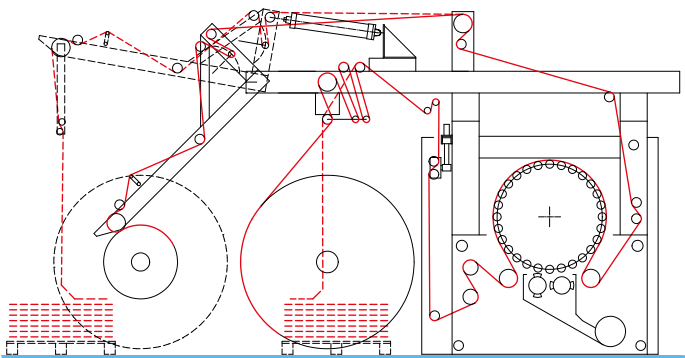

MC 10/36 INTANDEM WITH SHEARING



RAISING

Double drum raising machine MC 20/28 - MC 20/36



These double drum machines are suitable for processing all types of woven fabrics made from natural or synthetic fibre

They are available with 28 or 36 raising rollers, with a ranging from 1800 to 3600 mm to better adapt to fabrics of any width.

Equipped with an automatic zero point setting device.

As optional, thanks to the special **Seam Jumper®** (Crosta's patent) device for the automatic jumping of seams, production rejections around seams are eliminated and seams do not need to be repeated.

All raising parameters can be set both during machine standstill and while working.

PLUS

- » **Double ball bearing** system for each raising roller.
- » Two drum **vertical geometry** for space optimization.
- » **Automatic control device** for cleaning brushes.
- » **Semi-automatic drawing-in** device.
- » **Pneumatic tension control** of raising cylinders driving belts.
- » **Working hours counter** for preventive maintenance control.
- » **Touch-screen display** to guide and assist the operator during each operation phase.
- » **Driving system** with inverter-controlled three-phase motors and DC bus system.
- » An **air conditioner** installed on the upper section of the electric control box **keep the temperature constant** and **avoid the formation of condensate**, thus ensuring a long duration of all electric and electronic components.

Technical data

Installed power	90 kW
Effective energy consumption	40 kW
Compressed air min. pressure	5 bar
Adjustable production speed	10-40 m/min
Drum speed	70-120 rpm
Machine width	1800-3600 mm

Impact on the environment Compliant with all safety, EMC and noise European standards.

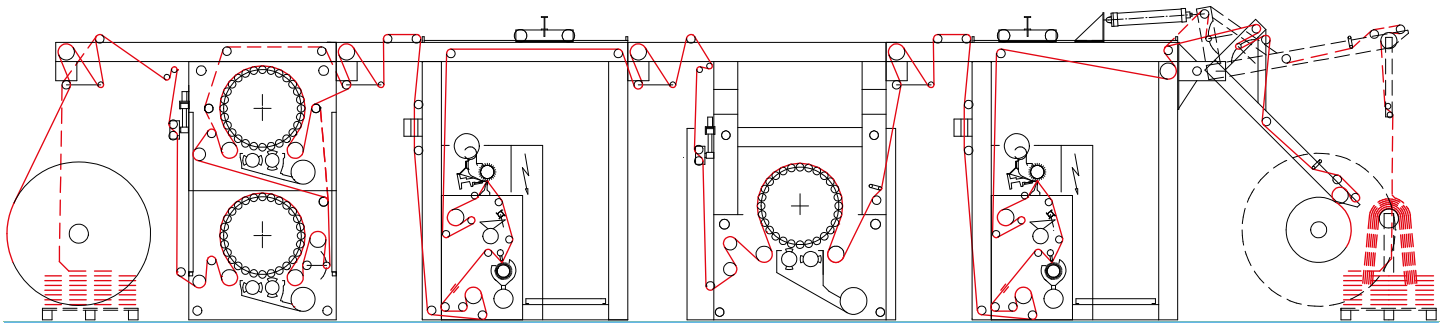

MC 20/28 INTANDEM WITH SHEARING

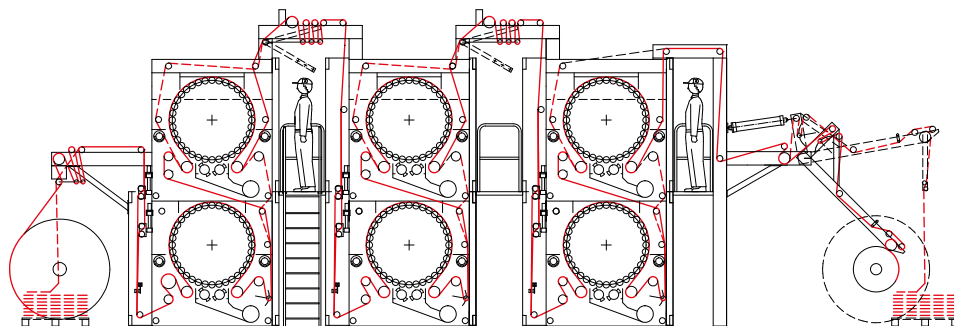

MC 20/36 THREE MACHINES IN TANDEM

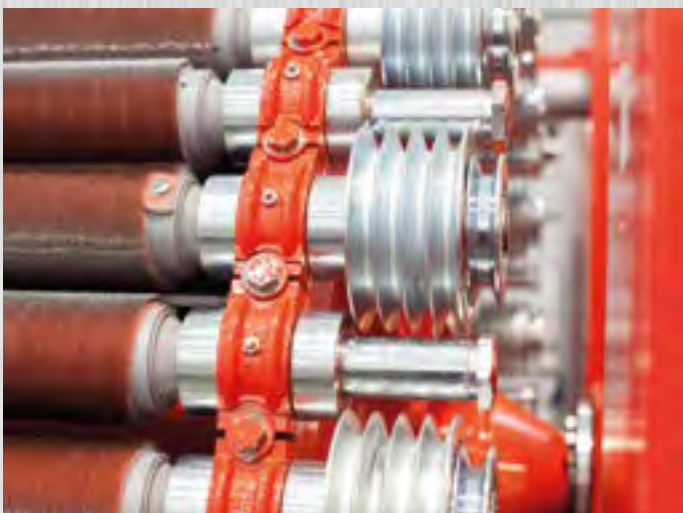

SHEARING

Shearing for Woven
TURBO - TURBO 11 - TURBO 20



Universal shearing machines for processing all types of fabric.

Available in different models, with one or more shearing groups:

Single unit shearing machine type SSC/a; SSC/a-11 type: one group to shear the right side and one to shear the back side;

SSC/a 20 type: two groups to shear the same side of the fabric.

Its ultimate release is represented by the **TURBO** system, a special cylinder and ledger blade anti-vibration system ensuring the absence of faults and a high production speed, also with particularly difficult fabrics, as well as a considerable reduction in sharpening operations compared with those machines not equipped with this system.

PLUS

- » **Automatic device** to move fabric backwards every time the machine stops.
- » **Device for rapid detachment of the shearing cylinder** from its ledger blade.
- » **Hoist for easy and quick replacement of the shearing group** to ease maintenance interventions.
- » **Automatic seam jumping** through the special sensors provided for seams detection. This way, the machine will automatically reject the minimum fabric quantity astride of seams.
- » Impulse running of each device **with independent driving system**.
- » **Working hours counter** for preventive maintenance control.
- » **Touch-screen display** to guide and assist the operator during each operation phase.
- » Programmer able to record up to **400 work programs**.
- » **Driving system** with inverter-controlled three-phase motors, as well as independent impulse controls for each device.
- » An **air conditioner** installed on the upper section of the electric control box **keep the temperature constant** and **avoid the formation of condensate**, thus ensuring a long duration of all electric and electronic components.

Technical data

Installed power	15 kW
Effective energy consumption	8 kW
Compressed air min. pressure	5 bar
Adjustable production speed	5-40 m/min
Cylinder speed	600-1200 rpm
Machine width	1800-3600 mm

Impact on the environment Compliant with all safety, EMC and noise European standards.

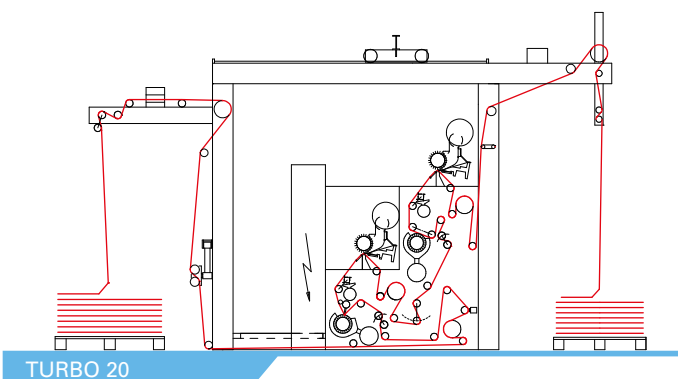
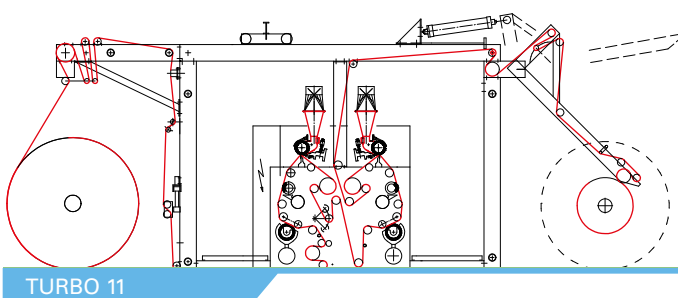
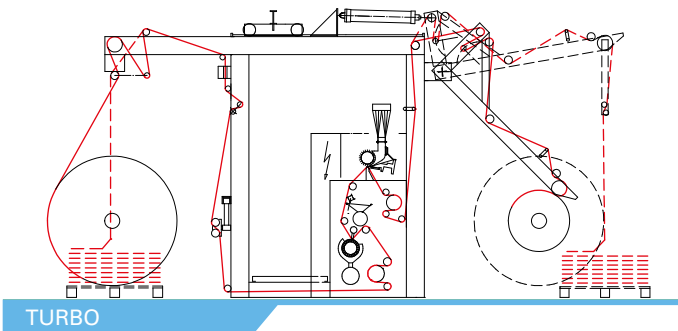

BRUSH SUEDING

Brush Sueding machine LISA 4.0 Woven



Model equipped with 4 brushes for the treatment of woven fabric.

It's divided in two independent modules, each of 2 brushes, module. The strength point of this machine is the possibility to set in the display the final effect required on the fabric as a parameter. The achievable result is independent on the fabric type and it remains constant during the time due to the electronic automatic adjustment of the machine.



PLUS

- » Suitable for **all kind of fibers**.
- » **Automatic seam guard**.
- » **Touch-screen display** for **parameters setting and control**.
- » Impulse running of each device with **independent driving system**.
- » **Working hours counter** for preventive maintenance control.
- » **Touch-screen display** to guide and **assist the operator** during each operation phase.
- » Programmer able to **record up to 400 work programs**.
- » **Driving system** with inverter-controlled three-phase motors and DC bus system.
- » An **air conditioner** installed on the upper section of the electric control box **keep the temperature constant** and **avoid the formation of condensate**, thus ensuring a long duration of all electric and electronic components.
- » **Automatic control of fabric tension**.
- » Possible installation of **different kinds of brushes**.

Technical data

Installed power	38 kW
Effective energy consumption	27 kW
Working width	1800-3200 mm
Adjustable production speed	5-40 m/min
Brush rotation	700-1500 rpm

Impact on the environment Compliant with all safety, EMC and noise European standards.

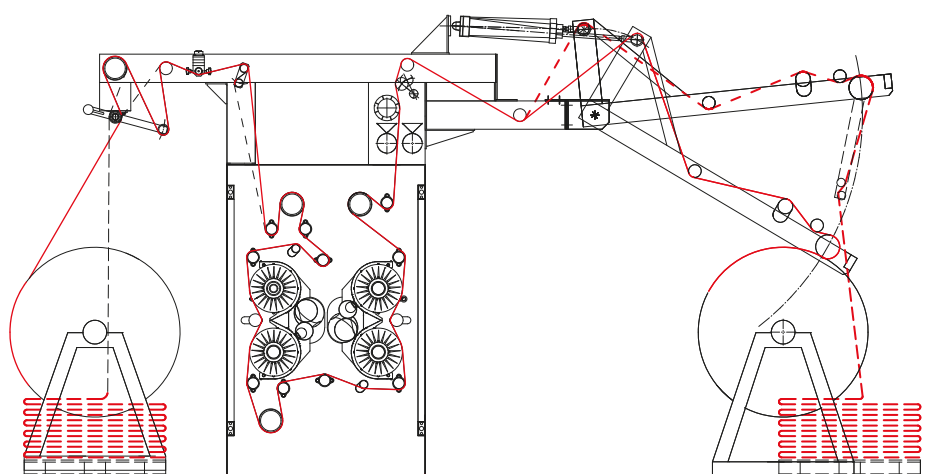

LISA 4.0 WOVEN



DIAMOND EMERY SUEDEDING

Diamond emery machine SANDY
Diamond emery machine SANDY²



This special diamond sueding machine benefits from the very latest materials for diamond emery manufacturing.

Sueding machine with 24 special cylinders, with independent variation of all working parameters, suitable for all types of woven fabrics.

Motor-driven draft cylinders with the Crosta programmer software power enables contact surface and Tangential sueding effect's completely automatic adjustment, thus allowing different fabrics interchanging, also without stopping the machine.



PLUS

- » **Semi-automatic drawing-in** device.
- » **Pneumatic tension control** of cylinders driving belts.
- » Impulse running of each device with **independent driving system**.
- » **Working hours counter** for preventive maintenance control.
- » **Touch-screen display** to guide and assist the operator during each operation phase.
- » Programmer able to **record up to 400 work programs**.
- » **Driving system** with inverter-controlled three-phase motors and DC bus system.
- » An **air conditioner installed** on the upper section of the electric control box **keep the temperature constant** and **avoid the formation of condensate**, thus ensuring a long duration of all electric and electronic components.

Technical data

Effective energy consumption	20 kW
Compressed air min. pressure	5 bar
Adjustable production speed	10-40 m/min
Drum speed	70-120 rpm
Machine width	1800-2600 mm

Impact on the environment Compliant with all safety, EMC and noise European standards.

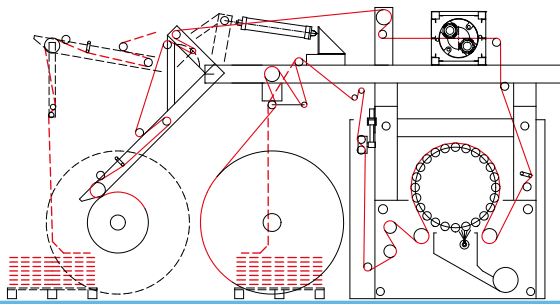

SANDY

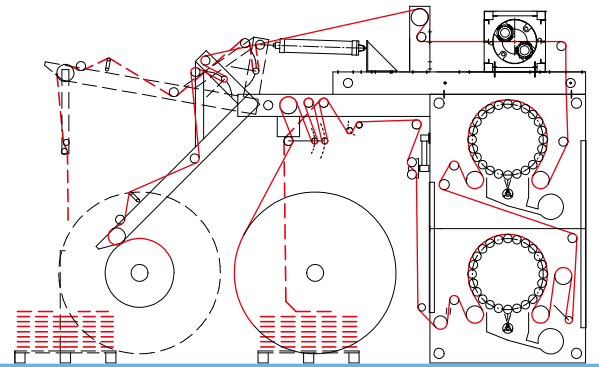

SANDY²





WORLDWIDE COVERAGE

With the largest global coverage of 70 countries, and the biggest amount of machines placed all over the world (more than 9.200 units), Mario Crosta is the oldest and biggest producer of textile face finishing company in the world.



SUSTAINABLE TECHNOLOGIES

Mario Crosta machines are chosen by the best and biggest brands in the world to reach and maintain the highest level of quality, not forgetting the lowest production costs, achieved thanks to the up-to-date technology, and the low impact on the environment. Mario Crosta, in fact, for many years, has chosen to become a symbol of Green technology.



OUR SERVICE

The after sale service has always been a goal Mario Crosta has always focused on. In addition to the headquarter division in Italy, which manages and organizes the requests from all over the world, a network of service centers throughout the globe ensures a fast and efficient service wherever customers are.



OUR MISSION

Mario Crosta Group, in business since 1925, aims at meeting every customer's demand in textile finishing with competence, timeliness and professionalism, through a highly motivated and involved team and a constant attention to research and development. We offer innovative high value-added solutions to meet any worldwide market's growing technological needs.

WOOL APPAREL

Raising
Shearing
Teasel
Wet Brushing
Decatizing
Polishing

WOVEN APPAREL

Raising
Shearing
Brush Sueding
Diamond Emery

KNIT APPAREL

Cotton Fleece
Performance Fleece
Polar Fleece
Brush Sueding
Shearing

HOME TEXTILE

Raising
Velvet Line
Shearing
Sueding

MARIO CROSTA

SINCE 1925



Mario Crosta s.r.l.

📍 21052 Busto Arsizio (VA) - Italy - Corso Sempione, 67

☎ +39 0331 631380 📠 +39 0331 631612

🌐 www.mariocrosta.com ✉ info@mariocrosta.com